

# **Hydra•Cell<sup>®</sup>**

**METERING SOLUTIONS<sup>™</sup>**

## **Electronic Precision Metering**

**Built to exceed API 675 performance standards  
with “pulse-free” linear flow**



<b>Contents</b>	<b>Page(s)</b>
Introduction . . . . .	3
Markets Served . . . . .	3
Primary Applications . . . . .	3
Fluid Handling Capability . . . . .	3
Operational & Cost Advantages . . . . .	4-5
Electronic Flow Control . . . . .	4
Choice of Materials . . . . .	4
Reduced Pulsations . . . . .	4-5
Economy through Technology . . . . .	5
Design Features & Performance Benefits . . . . .	6-7
API 675 Performance Standards . . . . .	8-9
Flow Capacities & Pressure Ratings . . . . .	10
Multiplex Capability . . . . .	11
Model Specifications & Ordering Information . . . . .	12-23
P100 . . . . .	12-13
P200 . . . . .	14-15
P300 . . . . .	16-17
P400 . . . . .	18-19
P500 . . . . .	20-21
P600 . . . . .	22-23
System Installation Example . . . . .	24
Accessories & Options . . . . .	24-25
Hydra-Cell Bare Shaft Pumps . . . . .	26
Worldwide Sales & Service . . . . .	27

“If the owner of a plant wants cost-effective pumps...he will buy pumps with the lowest Life Cycle Cost. Hydra-Cell is simple in construction, less elaborate in design and physically smaller for equivalent flow/pressure performance. These differences can substantially affect both purchase and operating costs.”

Dr. Ing Friedrich Wilhelm Hennecke  
*Chemical Engineering World*  
June 2006

# Hydra-Cell® is not an Ordinary Metering Pump

The technology used to produce ordinary metering pumps has barely changed in over a generation. As a result, ordinary metering pumps have operational limitations and greater cost consequences.

Hydra-Cell is not an ordinary metering pump. Hydra-Cell Metering Solutions pumps enable you to meet and, in most cases, exceed API 675 performance standards with virtually pulse-less, linear flow while providing many other operational benefits.

bility and linearity, while delivering precise, constant flow. This revolution in metering employs the latest available means of electronic flow control to replace antiquated, inaccurate stroke adjusters.

In addition, the modern design features of the Hydra-Cell pump lower your acquisition costs when compared to ordinary metering pumps, and its inherently simple yet elegant engineering keeps your maintenance and replacement costs down. Rugged construction and long-lasting durability will provide economy and value over the lifetime of your Hydra-Cell metering system.



Taking advantage of the most current technologies, Hydra-Cell P Series metering pumps achieve superior levels of accuracy, repeatability and linearity, while delivering precise, constant flow.

Used in place of ordinary metering pumps to provide superior performance at a lower cost, Hydra-Cell is an extraordinary metering pump built to handle your precise metering and dosing applications.

### Markets Served:

- Agriculture
- Biotech & Pharmaceutical
- Chemical Process
- Food & Beverage
- Glass & Clay
- Oil, Gas & Petrochemical
- Paints, Coatings, Sealants & Adhesives
- Pulp, Paper & Textiles
- Rubber & Plastics
- Water & Wastewater Treatment

### Primary Applications:

- Coating
- Dosing
- Filling
- Filtering
- Injecting
- Metering
- Mixing
- Printing
- Spraying
- Transferring

### Fluid Handling Capability:

<span style="font-size: 2em;">◀</span> <b>Non-Lubricating</b>	Propane/ Butane	Freon	Ammonia	Polymers	Fuels/ Additives	D.I. Water	Glycols	Chlorine	Acids/ Caustics	Glues/ Adhesives	Inks/ Paints	Resins	Slurries	<b>Viscous Abrasives</b> <span style="font-size: 2em;">▶</span>
---	--------------------	-------	---------	----------	---------------------	------------	---------	----------	--------------------	---------------------	-----------------	--------	----------	---

# Operational & Cost Advantages of Hydra-Cell Metering Solutions

## Electronic flow control is more accurate and reliable.

Ordinary metering pumps rely on manual stroke adjustment or expensive actuators to change flow. This can result in pumping inaccuracies, lost motion, operator error, and a greater chance of leakage.

Hydra-Cell uses Variable Frequency Drive (VFD) electronic flow adjustment to maintain greater accuracy throughout the turn-down range. It meets or exceeds API 675 performance standards while eliminating lost motion and a potential leak path.

Compared to many ordinary metering pumps, electronic flow control of Hydra-Cell reduces the chance of operator error and offers several other advantages:

Electronic Flow Control	Manual Stroke Adjusters/Actuators
Solid-state electronics (SCR, VFD, or solenoid pulser) are unlikely to fail	Stepper motors or linear actuators driving against pressure are subject to wear and tear
Metering is linear over the entire range	Losses in repeatability below 30% stroke length & losses through check valves
Volume per every stroke is constant and a known value	Unknown with manual stroke adjustment and may not be proportional to the output
Easy calibration of the desired feed rate	Nearly impossible to calibrate unless a variable stroke rate or span-able controller is used
Rate of change is virtually instantaneous (0 to max. RPM in 0.3 seconds)	Up to one (1) second per 1% of the stroke length

## Greater choice of materials enhances capability.

Ordinary metering pumps typically offer only PTFE diaphragms. When subjected to flex stresses, PTFE diaphragms do not have a “memory” like elastomeric diaphragms and will require more frequent and costly replacement due to stresses on the material. In addition, if fluid and process temperatures are low, and the PTFE diaphragm is cold, it can stiffen and cause irregularities in the output, and cause a drop in flow.

Hydra-Cell offers PTFE diaphragms as well as the following cost-effective elastomeric materials:

- Viton
- Buna
- EPDM
- Neoprene
- Aflas



A choice of diaphragm, check valve, and liquid end materials also enables Hydra-Cell pumps to operate over a wider range of processing applications. Plus, special materials such as Hastelloy C and Kynar are available in standard Hydra-Cell packages. Hydra-Cell is lower in cost compared to ordinary metering pumps that have substantial price adders for exotic liquid end materials.

## Reduced pulsations improve operation.

Ordinary metering pumps produce pulsing, surging flow and require large pulsation dampeners that add cost and complexity to a metering system. This inherent problem with ordinary metering pumps creates greater strain on the system and more wear and tear on the pump.

All Hydra-Cell models (except P100) feature a multiple diaphragm design that virtually eliminates pulsations and provides several benefits:

- Reduces pipe strain.
- Enhances operating safety.
- Minimizes maintenance.
- Reduces acceleration losses.
- Eliminates the need for pulsation dampeners.
- Lowers system acquisition costs.
- Provides accurate metering with linear, constant flow.

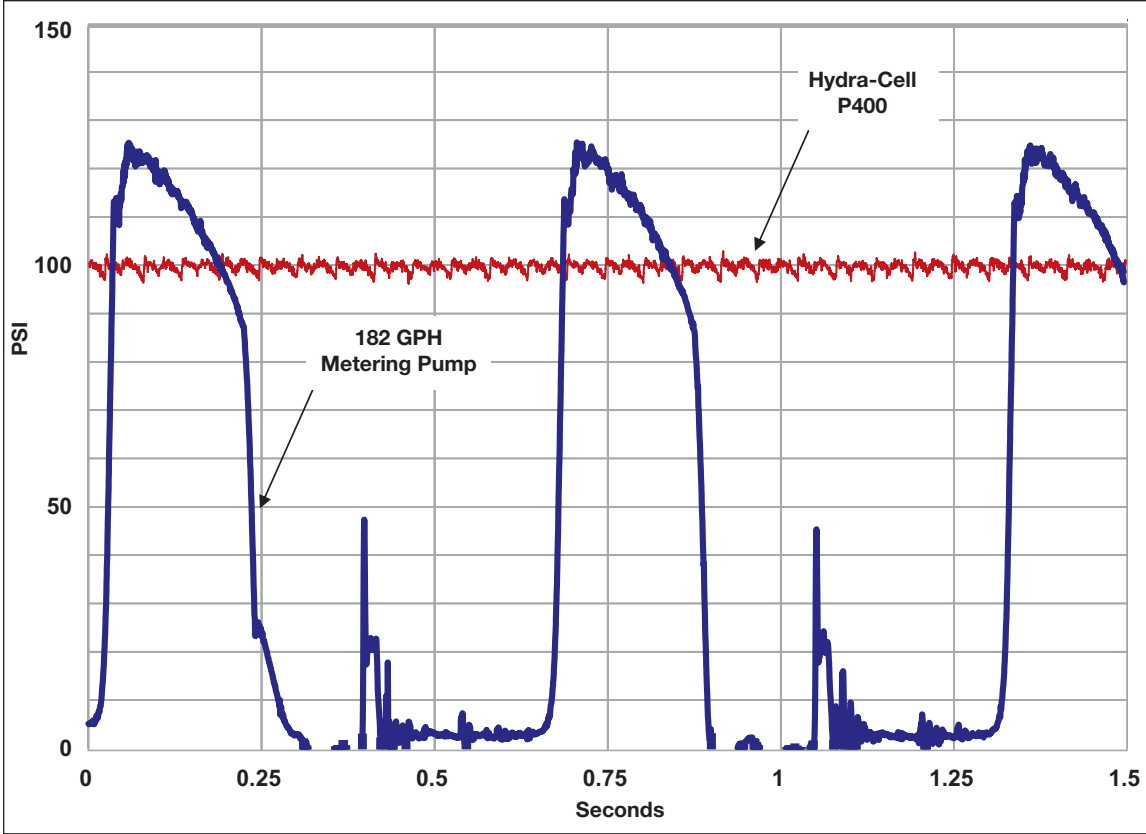

Compared to ordinary metering pumps operating under the same conditions at the same flow and pressure, Hydra-Cell Metering pumps provide smooth, almost pulse-less performance. This allows for the design of a safer, less expensive metering pump system and for use in more accurate applications, such as spraying which cannot tolerate pulsing flow.

**Achieve economy through technology.**

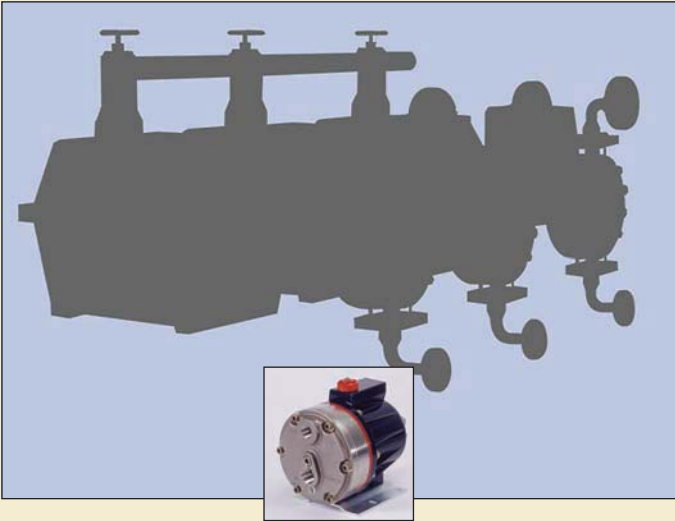

This Hydra-Cell pump shown to scale has the same flow capacity and pressure rating as an ordinary triplex metering pump – but has a much smaller footprint, saving you valuable real estate in your facility.

Ordinary metering pumps use technology in existence or unimproved upon for many years. This poses limitations such as inaccurate stroke adjusters, pulsation problems, limited choice of materials, narrow adjustable flow ranges, large footprints to handle high flows and pressures, different plunger and

diaphragm sizes, and difficulty handling slurries and suspended solids. Ordinary metering pumps result in higher costs of acquisition, maintenance, and replacement.

Hydra-Cell combines simple, elegant engineering with rugged construction to offer greater versatility while lowering life cycle costs. Design advantages include:

- Smaller footprint that offers the same capability as larger pumps – which are often over-sized and over-priced as flow and pressure requirements increase.
- Each model covers an extensive range of pressures and flows, whereas ordinary metering pumps may need different plunger and liquid end sizes to accommodate increases.
- The inherent simplicity of the Hydra-Cell design allows versatile application compared to complex metering pumps that require expensive construction changes to meet specific needs.
- Simplicity also means lower parts and maintenance costs.
- A separate gearbox allows greater versatility in changing applications and prevents cross-contamination of actuating oil – integral gearing on other pumps is difficult and expensive to change.

## Design Features & Performance Benefits of Hydra-Cell

### Separate Gearbox

Enables versatility in changing applications and prevents cross-contamination of actuating hydraulic oil.

### C-Face Motor Adapter

Makes it easier to install or replace motors. (Variety of NEMA & IEC motor frames also available.)

### Inherent Simplicity

Lowers acquisition costs, reduces maintenance costs, and minimizes labor costs.

### Lubricated Ball Bearings

Ensure optimal pump life.

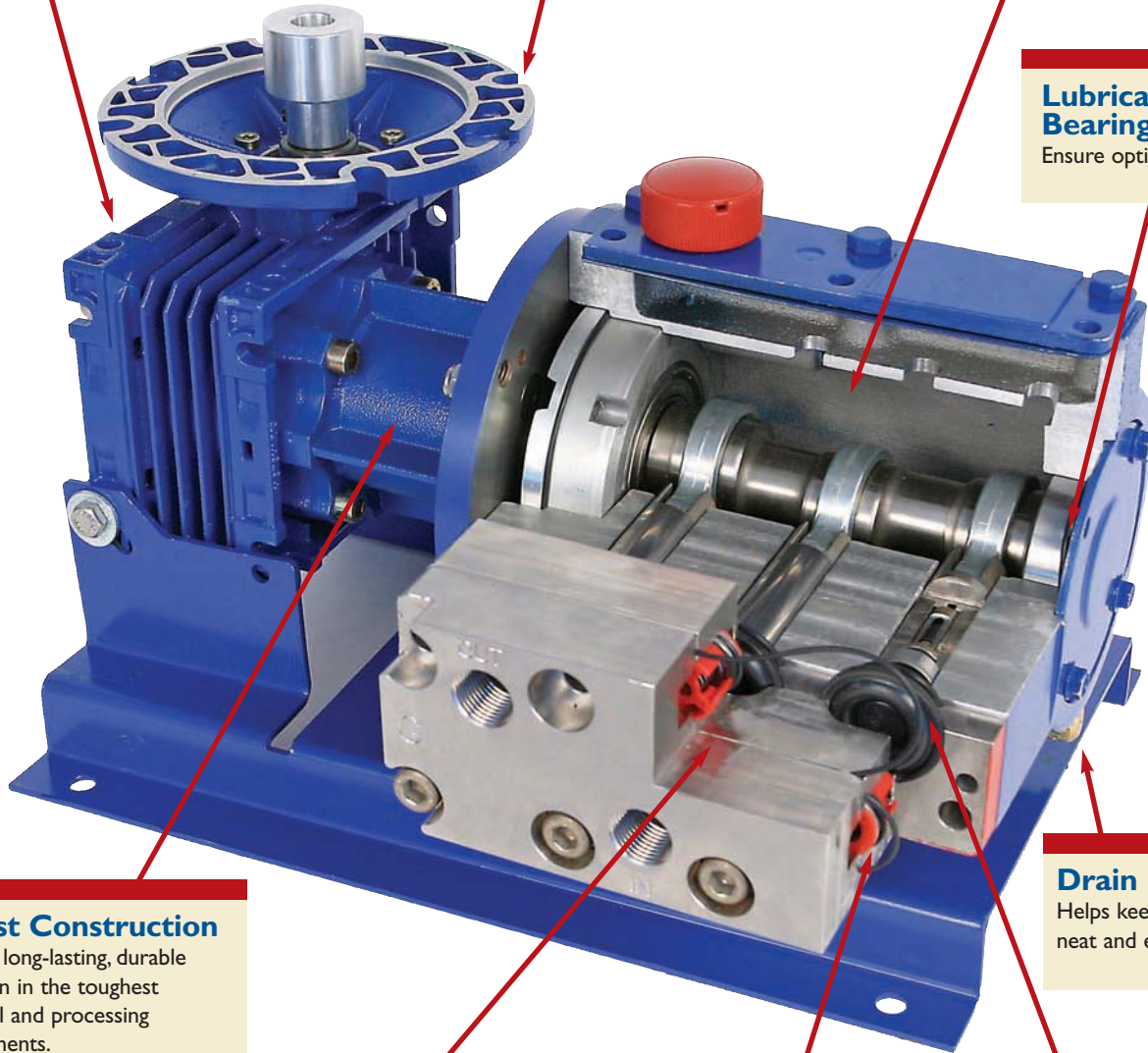

### Robust Construction

Delivers long-lasting, durable operation in the toughest industrial and processing environments.

### Drain Plug

Helps keep maintenance neat and easy.

### Extensive Choice of Materials

Choice of diaphragm, check valve, and liquid end materials allows pumps to operate in a wider range of applications.

### Spring-Loaded Disk Check Valves

Designed for superior handling of viscous fluids compared to floating, ball-style check valves.

### Multiple Diaphragms

Provide smooth, almost pulse-less performance with linear flow.

### Optimal Precision

Full stroke - every stroke.

### More Accurate

No manual stroke adjustment to cause inaccuracies, potential leakage and operator error.

### Variety of Flows & Pressures

Same plunger, liquid end and diaphragm size.

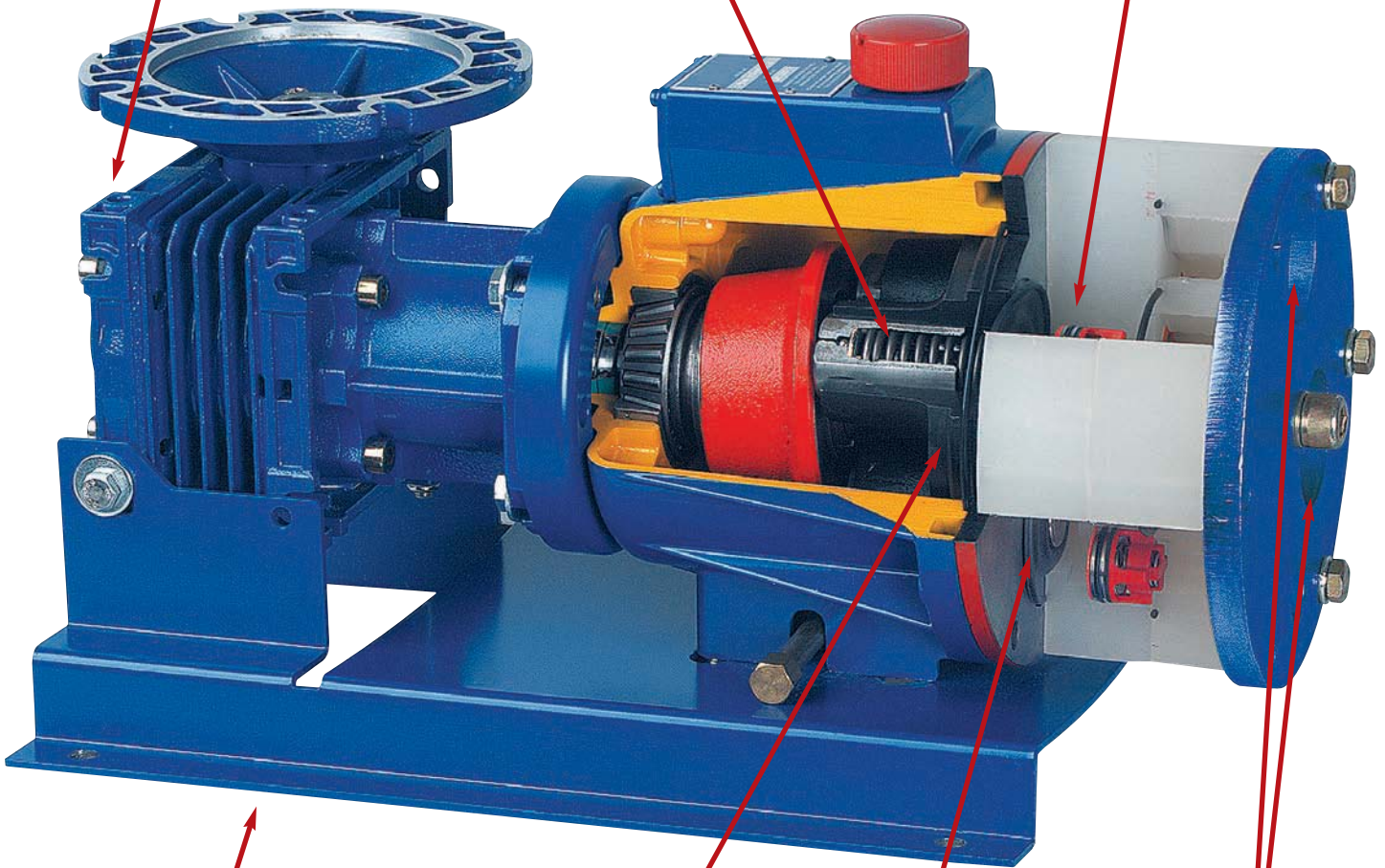

### Space-Saving

Significantly smaller footprint than comparably-rated metering pumps.

### Greater Repeatability

Replenishment valve for continuous accuracy.

### Linear Flow

Multiple diaphragms reduce pulsations and acceleration losses.

### Less Chance of Entrapped Air

Porting is larger than normal to eliminate common oxygen scavenger metering problems.

# Hydra-Cell Metering Solutions Pumps Meet or Exceed API 675 Performance Standards

In 1994, the American Petroleum Institute (API) adapted its Standard 675 to stipulate performance characteristics for controlled-volume, positive displacement pumps. Although revised in 2000, API 675 primarily defined pumps using mechanical stroke adjustment.

Hydra-Cell Metering Solutions meet or exceed API 675 performance standards by using electronic flow control to improve accuracy and a multi-diaphragm design to reduce pulsations. Used in precise metering, dosing, injection, and mixing applications, Hydra-Cell pumps provide an economical alternative to ordinary metering pumps.

## Operational Data for Testing

Pump Configuration:	P300NRGSS020S
Reducer:	20:1
PSI:	1500
Actuating Oil:	10W-30 Hydra-Oil
Ambient Temperature:	71.5°F
Pumped Fluid:	Water @72°F
Gravity Feed:	1-to-3 Feet Positive Head
Franklin IMDS Motor:	240-2400 RPM 1 HP

### Accuracy - Performance at a Set Point

For continuous metering applications, Hydra-Cell P Series pumps provide precise steady-state accuracy of  $\pm 1\%$  or better.

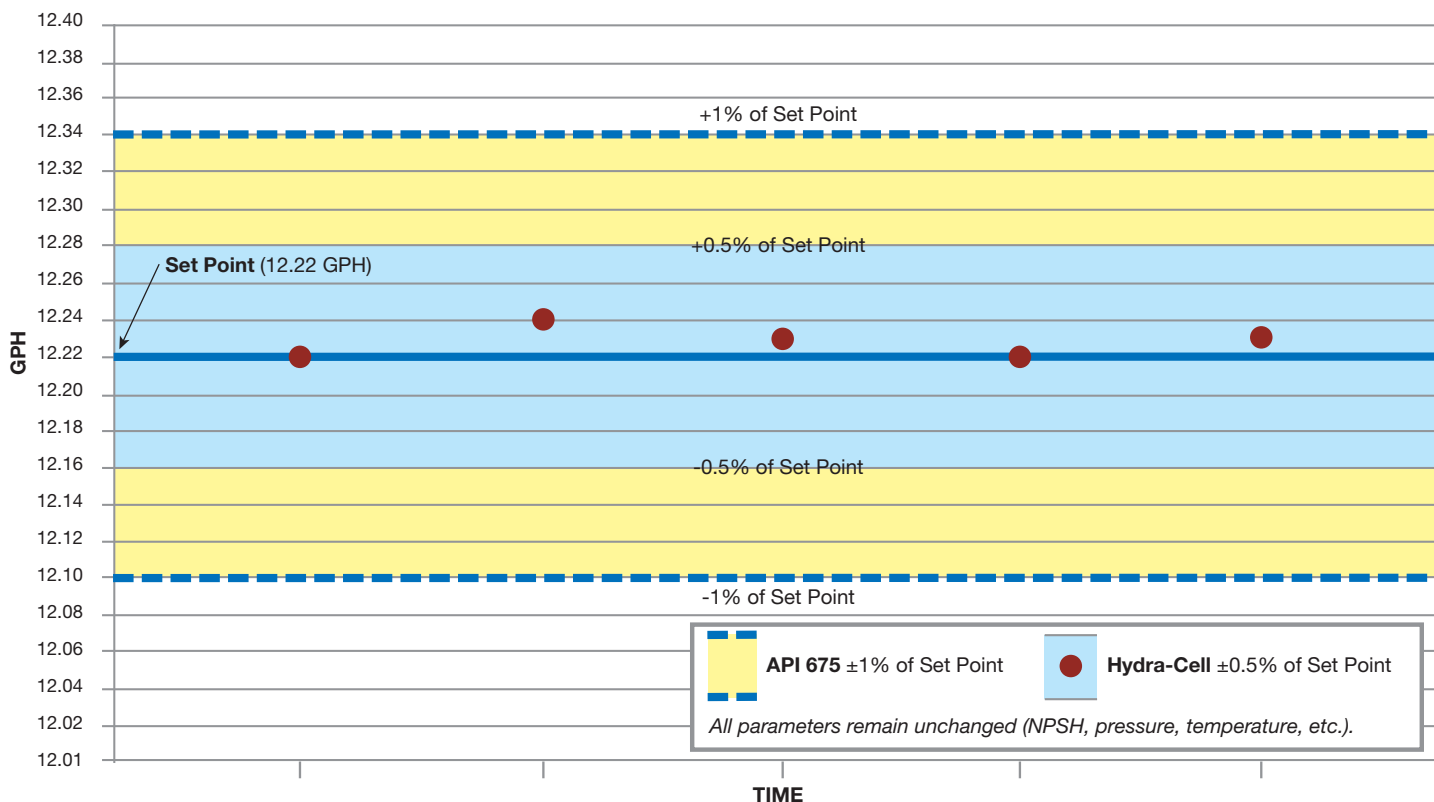

(Capacity measurements taken every 20 minutes after steady-state pumping achieved. Pump ran 40 minutes prior to first data point.)



### Linearity - Speed/Flow Rate Relationship

For smooth, virtually pulse-less performance, Hydra-Cell P Series pumps provide linear flow within  $\pm 3\%$  or better.

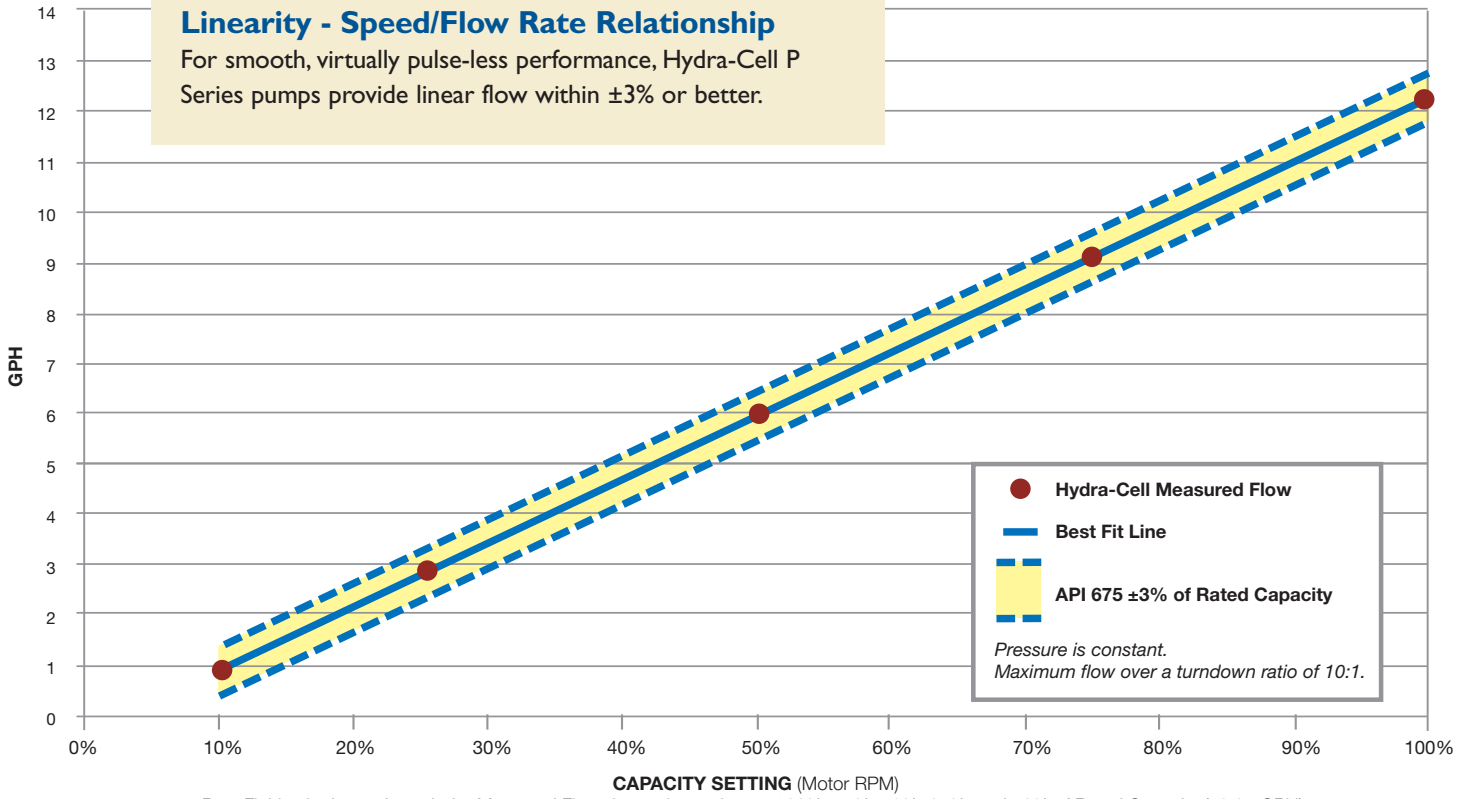

### Repeatability - Return to Set Conditions

Hydra-Cell P Series pumps always return to  $\pm 3\%$  or better of a set point condition after deviation (1200 RPM tested below).

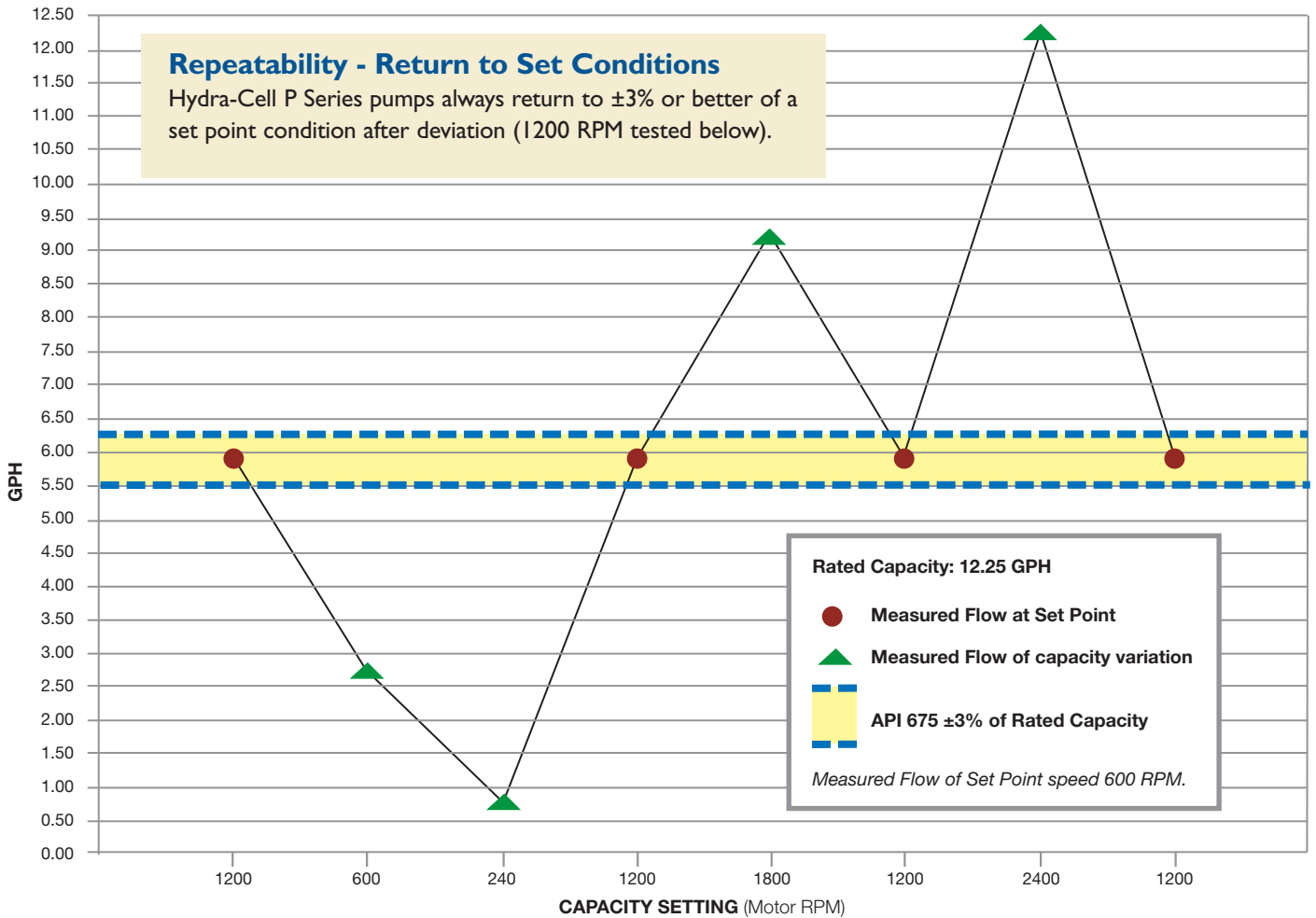

## Hydra-Cell Metering Solutions Capacities & Ratings

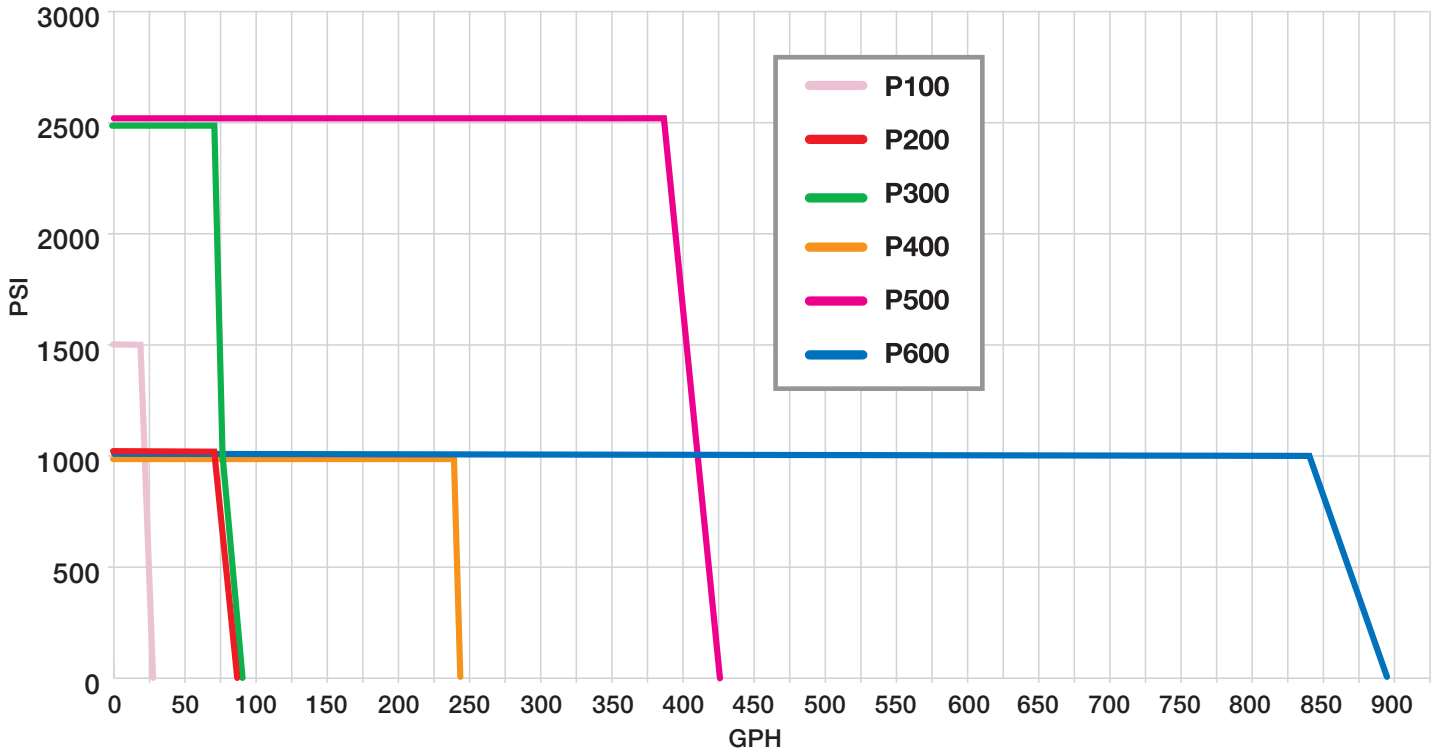

Hydra-Cell Metering Solutions pumps comprise six standard models, each with a wide range of flow capacities and pressure ratings to lower costly stocking requirements.

Hydra-Cell can also handle capacities greater than 894.6 GPH. See page 26 (Hydra-Cell Bare Shaft Pumps) or contact us for more information.

Model	Maximum Capacity (GPH)	Maximum Discharge Pressure (PSI)		Maximum Temperature (°F)**		Maximum Suction Pressure (PSI)	Specifications on Pages:
		Non-Metallic*	Metallic	Non-Metallic	Metallic		
P100	26.5	250	1500	140°	250°	250	12-13
P200	80.8	250	1000	140°	250°	250	14-15
P300	82.3	N/A	2500	N/A	250°	500	16-17
P400	243.0	250	1000	140°	250°	250	18-19
P500	426.0	N/A	2500	N/A	250°	500	20-21
P600	894.6	250	1000	140°	250°	250	22-23

\* 350 PSI (24 bar) maximum with Kynar® liquid end.

\*\* Consult factory for correct component selection for temperatures above 160°F (71°C).

## Multiplexing Capability

The simple design of Hydra-Cell enables mixing ratios of multiple fluids in flexible, economical ways. Using only one motor and one gearbox, Hydra-Cell Metering Solutions can provide spare, double-flow, side-by-side systems, or pre-mixed ratios. In fact, pumps utilizing the same gearbox and motor need not be the same model Hydra-Cell pumps. Up to six different fluids can be metered by using different manifold plates, and using special manifolds, a single Hydra-Cell P200 or P300 model can feed up to three systems from one liquid end. Ordinary metering pumps cannot provide the same capability without entailing the full cost of an additional pump.



*Manifold and valve plate for 2:1 ratio dosing applications*



*In this case, two P100 model pumps driven by one gearbox and one motor can meter two liquids.*

# PI00 Pump Series

Capacities to 26.5 GPH - Rated to 1500 PSI

Hydra-Cell Metering Solutions meet or exceed API 675 performance standards for Steady-State Accuracy ( $\pm 1\%$ ), Linearity ( $\pm 3\%$ ), and Repeatability ( $\pm 3\%$ ).

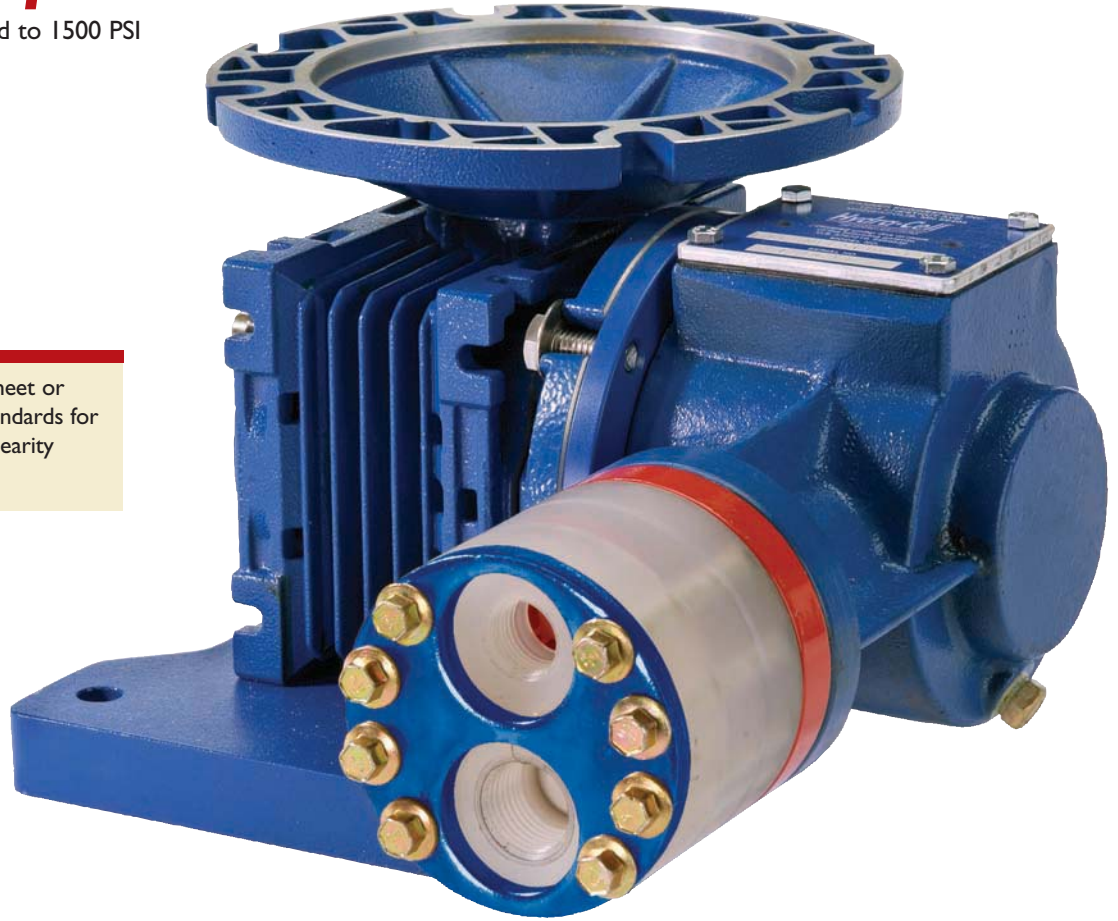

## Performance\*

GPH Maximum Flow at Designated Pressure

GPH All Pumps		GPH Metallic Pump Heads Only			Pump RPM	Gear Ratio	Motor RPM
100 PSI	250 PSI	500 PSI	1000 PSI	1500 PSI			
0.66	0.57	0.51	0.32	**	18	100:1	1800
0.82	0.73	0.67	0.48	**	22.5	80:1	
1.10	1.01	0.93	0.73	**	30	60:1	
1.32	1.22	1.14	0.94	**	36	50:1	
1.65	1.55	1.46	1.25	0.35	45	40:1	
2.20	2.10	2.00	1.76	0.85	60	30:1	
2.64	2.53	2.42	2.17	1.26	72	25:1	
3.31	3.18	3.06	2.79	1.86	90	20:1	
4.41	4.27	4.13	3.82	2.87	120	15:1	
6.62	6.45	6.26	5.87	4.88	180	10:1	
8.83	8.63	8.39	7.93	6.89	240	7.5:1	3600
13.20	12.98	12.64	12.04	10.92	360	5:1	
17.66	17.33	16.90	16.16	14.94	480	7.5:1	
26.50	26.04	25.42	24.38	22.99	720	5:1	

\* Capacity data is shown for pumps with elastomeric diaphragms. Consult factory for performance characteristics of pumps with PTFE diaphragms.

\*\* Consult factory for performance specifications.

### Required Motor HP

1/4    1/2    3/4

## Pump Data

Diaphragms per Liquid End	1
Flow Control	Electronic variable speed drive
Maximum Discharge Pressure	
Metallic Head:	1500 PSI (104 bar)
Non-Metallic Head:	Polypropylene- 250 PSI (17 bar) Kynar- 350 PSI (24 bar)
Maximum Suction Pressure	250 PSI (17 bar)
Maximum Temperature	
Metallic Head:	250°F (121°C)*
Non-Metallic Head:	140°F (60°C)
Suction Port	1/2 inch NPT or BSPT
Discharge Port	3/8 inch NPT or BSPT
Weight (less motor)	
Metallic Head:	18.5 lbs (8.4 kg)
Non-Metallic Head:	16.4 lbs (7.4 kg)
Dimensions (less motor)	
Metallic Head:	9.07" W x 11.57" D x 5.9" H (230 mm W x 294 mm D x 150 mm H)
Non-Metallic Head:	9.07" W x 11.82" D x 5.9" H (230 mm W x 300 mm D x 150 mm H)

\* Consult factory for correct component selection for temperatures above 160°F (71°C).

## Representative Dimensional Drawings

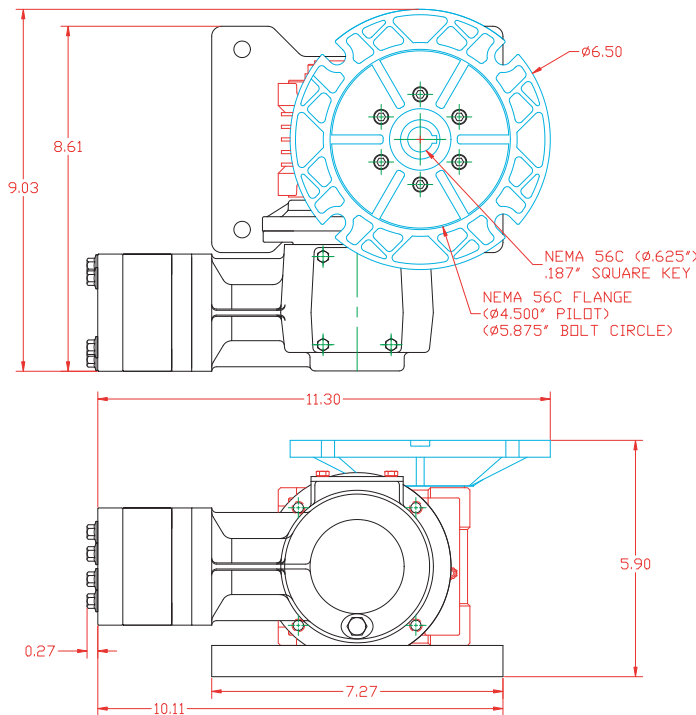

For accessories, options, and a system installation example, see pages 24-25.

## Pump Ordering Information

A complete pump order number contains 13 digits based on the specified pump materials listed below. Contact your Hydra-Cell sales representative for accompanying motor drive options.

1	2	3	4	5	6	7	8	9	10	11	12	13
P	I	0	0									

### Pump Model Size (Digits 1-4)

**P100** For all P100 Pumps

### Pump Version (Digit 5)

**N** NPT Ports  
**M** BSPT Ports

### Pump Head Material (Digit 6)

**M** Kynar®  
**P** Polypropylene  
**S** 316 Stainless Steel  
**T** Hastelloy® C

### Diaphragm & O-ring Material (Digit 7)

**E** EPDM  
**G** Viton®-XT  
**J** PTFE  
**P** Neoprene  
**T** Buna-N-XS

### Check Valve Material (Digits 8-9)

#### (Valve Spring / Valve & Seat)

**SS** 316 SST / 316 SST  
**TT** Hastelloy® C / Hastelloy® C  
**SC** 316 SST / Ceramic  
**TC** Hastelloy® C / Ceramic

### Gearbox Ratio (Digits 10-12)

**100** 100:1 (56C Motor Frame)  
**080** 80:1 (56C Motor Frame)  
**060** 60:1 (56C Motor Frame)  
**050** 50:1 (56C Motor Frame)  
**040** 40:1 (56C Motor Frame)  
**030** 30:1 (56C Motor Frame)  
**025** 25:1 (56C Motor Frame)  
**020** 20:1 (56C Motor Frame)  
**015** 15:1 (56C Motor Frame)  
**010** 10:1 (56C Motor Frame)  
**007** 7.5:1 (56C Motor Frame)  
**005** 5:1 (56C Motor Frame)

### Base Plate (Digit 13)

**A** Aluminum (Epoxy painted)

# P200 Pump Series

Capacities to 80.8 GPH - Rated to 1000 PSI

Hydra-Cell Metering Solutions meet or exceed API 675 performance standards for Steady-State Accuracy ( $\pm 1\%$ ), Linearity ( $\pm 3\%$ ), and Repeatability ( $\pm 3\%$ ).



## Performance\*

GPH Maximum Flow at Designated Pressure

GPH All Pumps		GPH Metallic Pump Heads Only		Pump RPM	Gear Ratio	Motor RPM
100 PSI	250 PSI	500 PSI	1000 PSI			
1.70	1.60	1.40	0.90	18	100:1	
2.21	2.10	1.90	1.38	22.5	80:1	
3.05	2.94	2.73	2.18	30	60:1	
3.73	3.62	3.39	2.81	36	50:1	
4.74	4.62	4.39	3.77	45	40:1	
6.43	6.30	6.05	5.36	60	30:1	1800
7.78	7.65	7.38	6.64	72	25:1	
9.81	9.67	9.37	8.55	90	20:1	
13.18	13.03	12.69	11.74	120	15:1	
19.94	19.75	19.34	18.12	180	10:1	
26.69	26.47	25.98	24.50	240	7.5:1	
40.20	39.92	39.26	37.25	360	5:1	
53.71	53.36	52.55	50.00	480	7.5:1	3600
80.72	80.25	79.11	75.51	720	5:1	

\* Capacity data is shown for pumps with elastomeric diaphragms. Consult factory for performance characteristics of pumps with PTFE diaphragms.

### Required Motor HP

1/4	1/2	3/4	1
-----	-----	-----	---

## Pump Data

Diaphragms per Liquid End	3
Flow Control	Electronic variable speed drive
Maximum Discharge Pressure	
Metallic Head:	1000 PSI (70 bar)
Non-Metallic Head:	Polypropylene- 250 PSI (17 bar) Kynar- 350 PSI (24 bar)
Maximum Suction Pressure	250 PSI (17 bar)
Maximum Temperature	
Metallic Head:	250°F (121°C)*
Non-Metallic Head:	140°F (60°C)
Suction Port	1/2 inch NPT or BSPT
Discharge Port	3/8 inch NPT or BSPT
Weight (less motor)	
Metallic Head:	39 lbs (17.7 kg)
Non-Metallic Head:	30 lbs (13.6 kg)
Dimensions (less motor)	
Metallic Head:	15.56" W x 12.23" D x 8.06" H (395 mm W x 311 mm D x 205 mm H)
Non-Metallic Head:	15.56" W x 12.61" D x 8.06" H (395 mm W x 320 mm D x 205 mm H)

\* Consult factory for correct component selection for temperatures above 160°F (71°C).

## Representative Dimensional Drawings

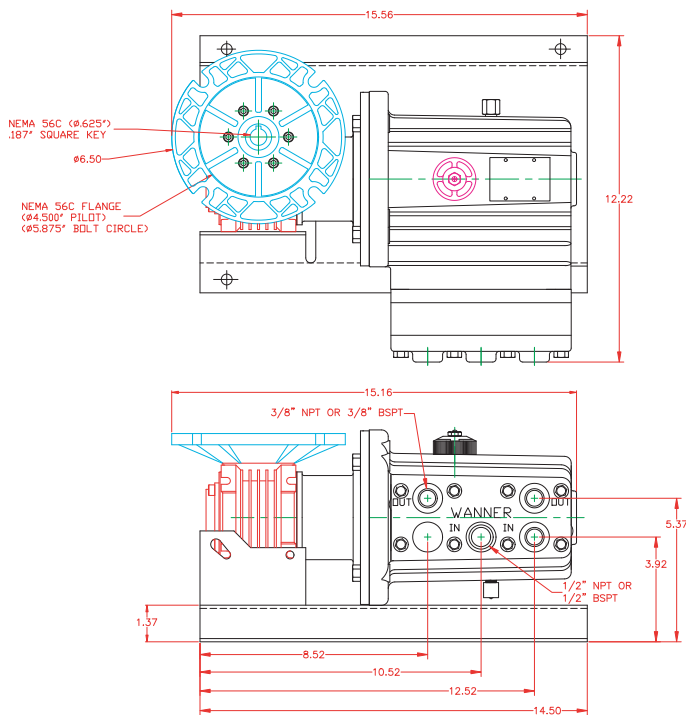

For accessories, options, and a system installation example, see pages 24-25.

## Pump Ordering Information

A complete pump order number contains 13 digits based on the specified pump materials listed below. Contact your Hydra-Cell sales representative for accompanying motor drive options.

1	2	3	4	5	6	7	8	9	10	11	12	13
P	2	0	0									

### Pump Model Size (Digits 1-4)

**P200** For all P200 Pumps

### Pump Version (Digit 5)

**N** NPT Ports  
**M** BSPT Ports

### Pump Head Material (Digit 6)

**M** Kynar®  
**P** Polypropylene  
**S** 316 Stainless Steel  
**T** Hastelloy® C

### Diaphragm & O-ring Material (Digit 7)

**E** EPDM  
**G** Viton®-XT  
**J** PTFE  
**P** Neoprene  
**T** Buna-N-XS

### Check Valve Material (Digits 8-9)

#### (Valve Spring / Valve & Seat)

**SS** 316 SST / 316 SST  
**TT** Hastelloy® C / Hastelloy® C  
**SC** 316 SST / Ceramic  
**TC** Hastelloy® C / Ceramic

### Gearbox Ratio (Digits 10-12)

<b>100</b>	100:1	(56C Motor Frame)
<b>080</b>	80:1	(56C Motor Frame)
<b>060</b>	60:1	(56C Motor Frame)
<b>050</b>	50:1	(56C Motor Frame)
<b>040</b>	40:1	(56C Motor Frame)
<b>030</b>	30:1	(56C Motor Frame)
<b>025</b>	25:1	(56C Motor Frame)
<b>020</b>	20:1	(56C Motor Frame)
<b>015</b>	15:1	(56C Motor Frame)
<b>010</b>	10:1	(56C Motor Frame)
<b>007</b>	7.5:1	(56C Motor Frame)
<b>005</b>	5:1	(56C Motor Frame)

### Base Plate (Digit 13)

**C** Carbon Steel (Epoxy painted)  
**S** Stainless Steel

# P300 Pump Series

Capacities to 82.3 GPH - Rated to 2500 PSI

Hydra-Cell Metering Solutions meet or exceed API 675 performance standards for Steady-State Accuracy ( $\pm 1\%$ ), Linearity ( $\pm 3\%$ ), and Repeatability ( $\pm 3\%$ ).

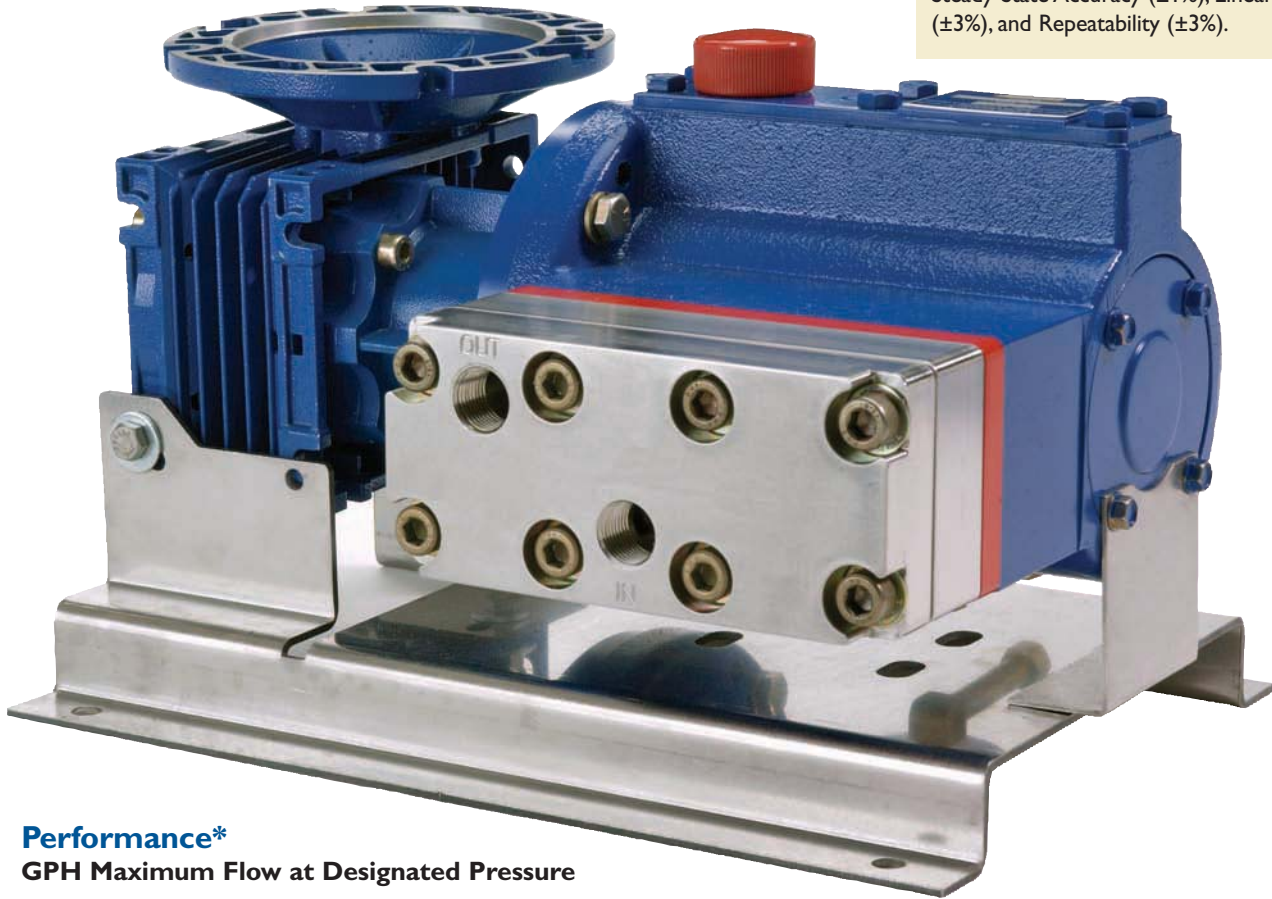

## Performance\*

GPH Maximum Flow at Designated Pressure

GPH Metallic Pump Heads Only				Pump RPM	Gear Ratio	Motor RPM
100 PSI	500 PSI	1500 PSI	2500 PSI			
2.00	1.85	1.50	1.15	18	100:1	1800
2.51	2.36	1.98	1.60	22.5	80:1	
3.37	3.21	2.79	2.36	30	60:1	
4.06	3.88	3.43	2.97	36	50:1	
5.09	4.89	4.40	3.88	45	40:1	
6.80	6.58	6.01	5.39	60	30:1	
8.17	7.94	7.30	6.60	72	25:1	
10.23	9.62	9.23	8.41	90	20:1	
13.66	13.34	12.46	11.44	120	15:1	
20.52	20.10	18.90	17.50	180	10:1	
27.38	26.86	25.35	23.55	240	7.5:1	
41.10	40.37	38.24	35.67	360	5:1	3600
54.82	53.89	51.13	47.78	480	7.5:1	
82.26	80.91	76.91	72.00	720	5:1	

\* Capacity data is shown for pumps with elastomeric diaphragms. Consult factory for performance characteristics of pumps with PTFE diaphragms.

### Required Motor HP

1/4	1/2	3/4	1
1-1/2	2	3	



## Pump Data

Diaphragms per Liquid End	3
Flow Control	Electronic variable speed drive
Maximum Discharge Pressure	
Metallic Head:	2500 PSI (173 bar)
Maximum Suction Pressure	500 PSI (35 bar)
Maximum Temperature	
Metallic Head:	250°F (121°C)*
Suction Port	1/2 inch NPT or BSPT
Discharge Port	1/2 inch NPT or BSPT
Weight (less motor)	
Metallic Head:	51 lbs. (23.2 kg)
Dimensions (less motor)**	
Metallic Head:	16.02" W x 12.23" D x 9.60" H (407 mm W x 311 mm D x 244 mm H)

\* Consult factory for correct component selection for temperatures above 160°F (71°C).  
 \*\* For 56C motor frame only. Consult factory for other motor frame sizes.

## Representative Dimensional Drawings

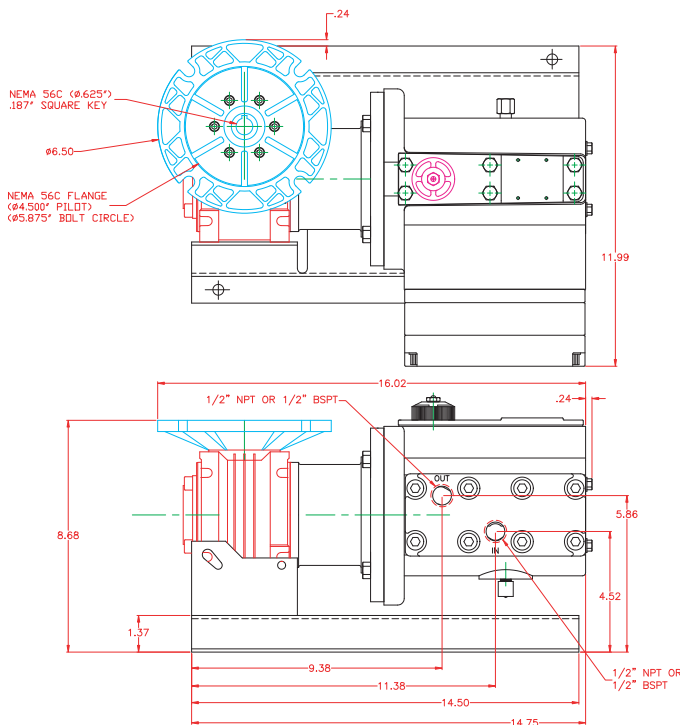

For accessories, options, and a system installation example, see pages 24-25.

## Pump Ordering Information

A complete pump order number contains 13 digits based on the specified pump materials listed below. Contact your Hydra-Cell sales representative for accompanying motor drive options.

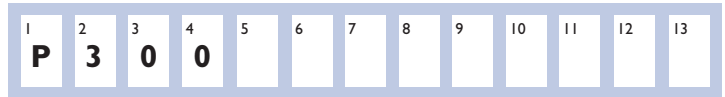

### Pump Model Size (Digits 1-4)

**P300** For all P300 Pumps

### Pump Version (Digit 5)

**N** NPT Ports  
**M** BSPT Ports

### Pump Head Material (Digit 6)

**R** 304 Stainless Steel  
**S** 316 Stainless Steel  
**T** Hastelloy® C

### Diaphragm & O-ring Material (Digit 7)

**G** Viton®-XT  
**T** Buna-N-XS

### Check Valve Material (Digits 8-9)

#### (Valve Spring / Valve & Seat)

**SS** 316 SST / 316 SST  
**TT** Hastelloy® C / Hastelloy® C

### Gearbox Ratio (Digits 10-12)

<b>100</b>	100:1	(56C Motor Frame)
<b>080</b>	80:1	(56C Motor Frame)
<b>060</b>	60:1	(56C Motor Frame)
<b>050</b>	50:1	(56C Motor Frame)
<b>040</b>	40:1	(56C Motor Frame)
<b>030</b>	30:1	(56C Motor Frame)
<b>025</b>	25:1	(56C Motor Frame)
<b>020</b>	20:1	(56C Motor Frame)
<b>015</b>	15:1	(56C Motor Frame)
<b>010</b>	10:1	(56C Motor Frame)
<b>007</b>	7.5:1	(56C Motor Frame)
<b>A07</b>	7.5:1	(143/145TC Motor Frame)
<b>005</b>	5:1	(56C Motor Frame)
<b>A05</b>	5:1	(143/145TC Motor Frame)

### Base Plate (Digit 13)

**C** Carbon Steel (Epoxy painted)  
**S** Stainless Steel

# P400 Pump Series

Capacities to 243.0 GPH - Rated to 1000 PSI



Hydra-Cell Metering Solutions meet or exceed API 675 performance standards for Steady-State Accuracy ( $\pm 1\%$ ), Linearity ( $\pm 3\%$ ), and Repeatability ( $\pm 3\%$ ).

## Performance\*

GPH Maximum Flow at Designated Pressure

GPH All Pumps		GPH Metallic Pump Heads Only		Pump RPM	Gear Ratio	Motor RPM
100 PSI	250 PSI	500 PSI	1000 PSI			
5.45	5.40	5.35	5.19	18	100:1	
6.97	6.92	6.86	6.68	22.5	80:1	
9.51	9.45	9.38	9.16	30	60:1	
11.54	11.48	11.40	11.15	36	50:1	
14.59	14.52	14.43	14.13	45	40:1	
19.66	19.59	19.47	19.10	60	30:1	1800
23.72	23.64	23.51	23.07	72	25:1	
29.81	29.72	29.56	29.04	90	20:1	
39.96	39.85	39.65	38.97	120	15:1	
60.27	60.12	59.83	58.84	180	10:1	
80.57	80.38	80.00	78.71	240	7.5:1	
121.2	120.9	120.4	118.5	360	5:1	
161.8	161.4	160.7	158.2	480	7.5:1	3600
243.0	242.5	241.4	237.7	720	5:1	

\* Capacity data is shown for pumps with elastomeric diaphragms. Consult factory for performance characteristics of pumps with PTFE diaphragms.

### Required Motor HP

1/4	1/2	3/4	1
1-1/2	2	3	

## Pump Data

Diaphragms per Liquid End	3
Flow Control	Electronic variable speed drive
Maximum Discharge Pressure	
Metallic Head:	1000 PSI (70 bar)
Non-Metallic Head:	Polypropylene- 250 PSI (17 bar) Kynar- 350 PSI (24 bar)
Maximum Suction Pressure	250 PSI (17 bar)
Maximum Temperature	
Metallic Head:	250°F (121°C)*
Non-Metallic Head:	140°F (60°C)
Suction Port	1 inch NPT or BSPT
Discharge Port	3/4 inch NPT or BSPT
Weight (less motor)	
Metallic Head:	62 lbs (28.1 kg)
Non-Metallic Head:	49 lbs (22.2 kg)
Dimensions (less motor)**	
Metallic Head:	17.59" W x 9.87" D x 10.34" H (447 mm W x 251 mm D x 263 mm H)
Non-Metallic Head:	18.19" W x 9.87" D x 10.34" H (462 mm W x 251 mm D x 263 mm H)

\* Consult factory for correct component selection for temperatures above 160°F (71°C).

\*\* For 56C motor frame only. Consult factory for other motor frame sizes.

## Representative Dimensional Drawings

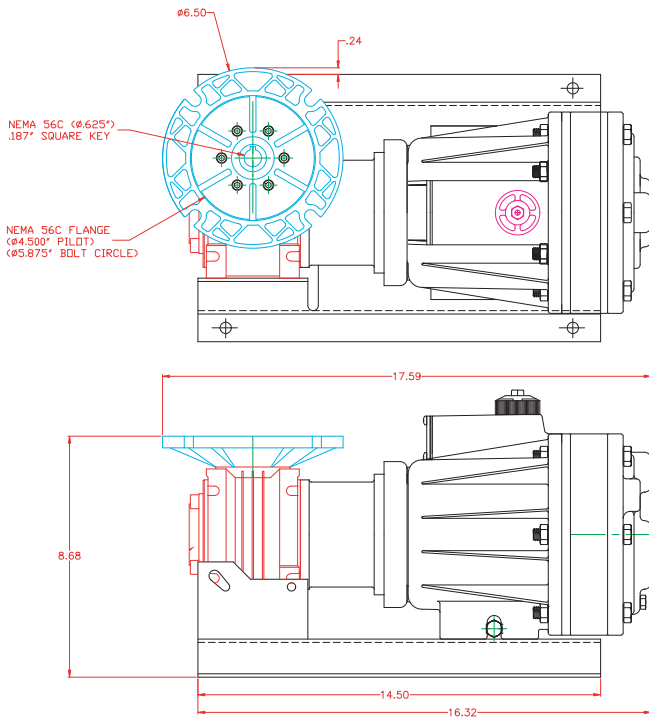

For accessories, options, and a system installation example, see pages 24-25.

## Pump Ordering Information

A complete pump order number contains 13 digits based on the specified pump materials listed below. Contact your Hydra-Cell sales representative for accompanying motor drive options.

1	2	3	4	5	6	7	8	9	10	11	12	13
P	4	0	0									

### Pump Model Size (Digits 1-4)

**P400** For all P400 Pumps

### Pump Version (Digit 5)

**N** NPT Ports  
**M** BSPT Ports

### Pump Head Material (Digit 6)

**C** Cast Iron  
**M** Kynar®  
**P** Polypropylene  
**S** 316 Stainless Steel  
**T** Hastelloy® C

### Diaphragm & O-ring Material (Digit 7)

**E** EPDM  
**G** Viton®-XT  
**J** PTFE  
**P** Neoprene  
**T** Buna-N-XS

### Check Valve Material (Digits 8-9)

#### (Valve Spring / Valve & Seat)

**SS** 316 SST / 316 SST  
**TT** Hastelloy® C / Hastelloy® C  
**SC** 316 SST / Ceramic  
**TC** Hastelloy® C / Ceramic

### Gearbox Ratio (Digits 10-12)

<b>100</b>	100:1	(56C Motor Frame)
<b>080</b>	80:1	(56C Motor Frame)
<b>060</b>	60:1	(56C Motor Frame)
<b>050</b>	50:1	(56C Motor Frame)
<b>040</b>	40:1	(56C Motor Frame)
<b>030</b>	30:1	(56C Motor Frame)
<b>025</b>	25:1	(56C Motor Frame)
<b>020</b>	20:1	(56C Motor Frame)
<b>015</b>	15:1	(56C Motor Frame)
<b>010</b>	10:1	(56C Motor Frame)
<b>007</b>	7.5:1	(56C Motor Frame)
<b>A07</b>	7.5:1	(143/145TC Motor Frame)
<b>005</b>	5:1	(56C Motor Frame)
<b>A05</b>	5:1	(143/145TC Motor Frame)

### Base Plate (Digit 13)

**C** Carbon Steel (Epoxy painted)  
**S** Stainless Steel

# P500 Pump Series

Capacities to 426.0 GPH - Rated to 2500 PSI

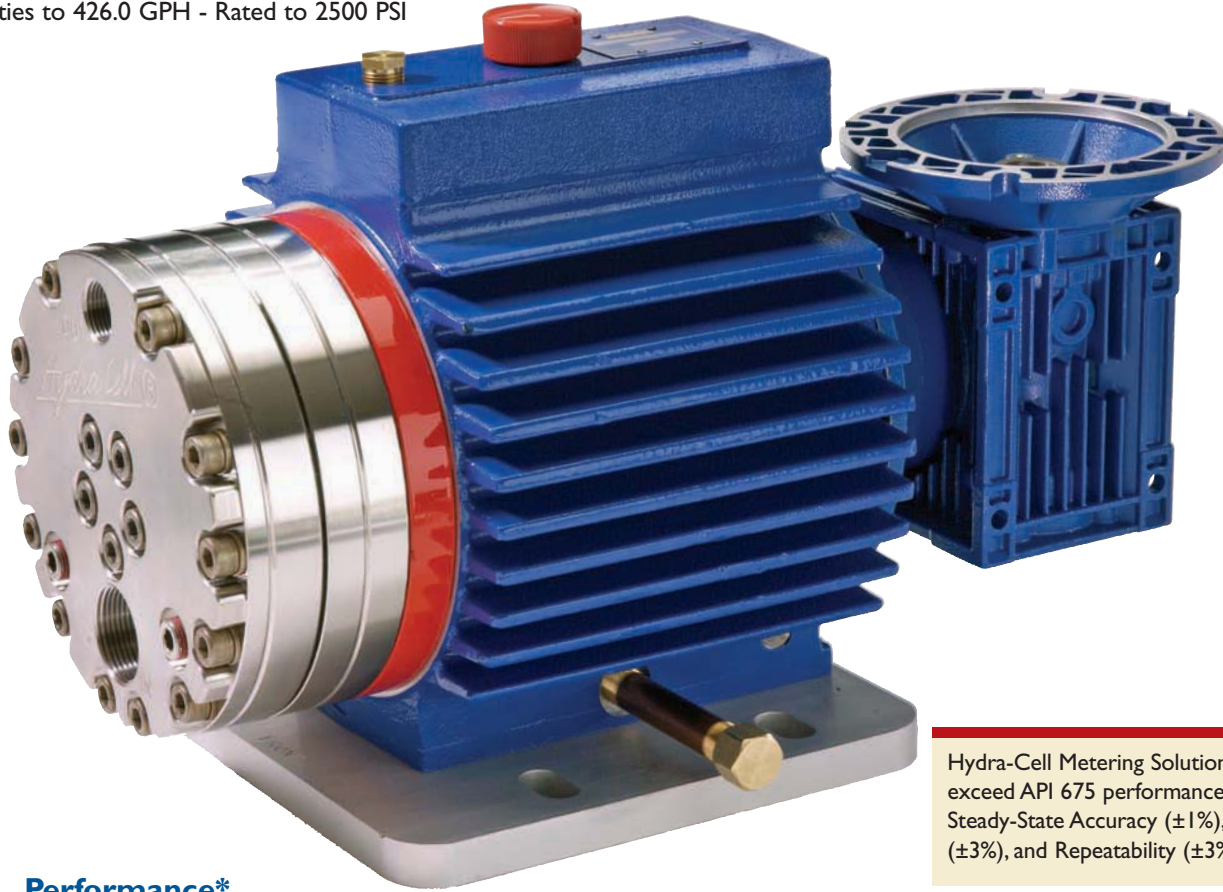

Hydra-Cell Metering Solutions meet or exceed API 675 performance standards for Steady-State Accuracy ( $\pm 1\%$ ), Linearity ( $\pm 3\%$ ), and Repeatability ( $\pm 3\%$ ).

## Performance\*

GPH Maximum Flow at Designated Pressure

GPH Metallic Pump Heads Only				Pump RPM	Gear Ratio	Motor RPM
100 PSI	500 PSI	1500 PSI	2500 PSI			
11.74	11.26	10.25	9.47	18	100:1	1800
14.39	13.89	12.79	11.89	22.5	80:1	
18.82	18.27	17.02	15.92	30	60:1	
22.36	21.78	20.41	19.15	36	50:1	
27.67	27.03	25.49	23.99	45	40:1	
36.52	35.80	33.95	32.06	60	30:1	
43.60	42.81	40.73	38.52	72	25:1	
54.22	53.32	50.89	48.20	90	20:1	
71.93	70.84	67.82	64.34	120	15:1	
107.3	105.9	101.7	96.62	180	10:1	
142.7	140.9	135.5	128.9	240	7.5:1	3600
213.6	211.0	203.3	193.5	360	5:1	
284.4	281.1	271.0	258.0	480	7.5:1	
426.0	421.3	406.5	387.1	720	5:1	

\* Capacity data is shown for pumps with elastomeric diaphragms. Consult factory for performance characteristics of pumps with PTFE diaphragms.

### Required Motor HP

1/4	1/2	3/4	1	1-1/2	2
3	5	7-1/2	10	15	

## Pump Data

Diaphragms per Liquid End	5
Flow Control	Electronic variable speed drive
Maximum Discharge Pressure	
Metallic Head:	2500 PSI (173 bar)
Maximum Suction Pressure	500 PSI (35 bar)
Maximum Temperature	
Metallic Head:	250°F (121°C)*
Suction Port	1-1/4 inch NPT or BSPT
Discharge Port	3/4 inch NPT or BSPT
Weight (less motor)	
Metallic Head:	160 lbs (72.6 kg)
Dimensions (less motor)**	
Metallic Head:	19.2" W x 10.7" D x 12.4" H (488 mm W x 272 mm D x 315 mm H)

\* Consult factory for correct component selection for temperatures above 160°F (71°C).  
 \*\* For 56C motor frame only. Consult factory for other motor frame sizes.

## Representative Dimensional Drawings

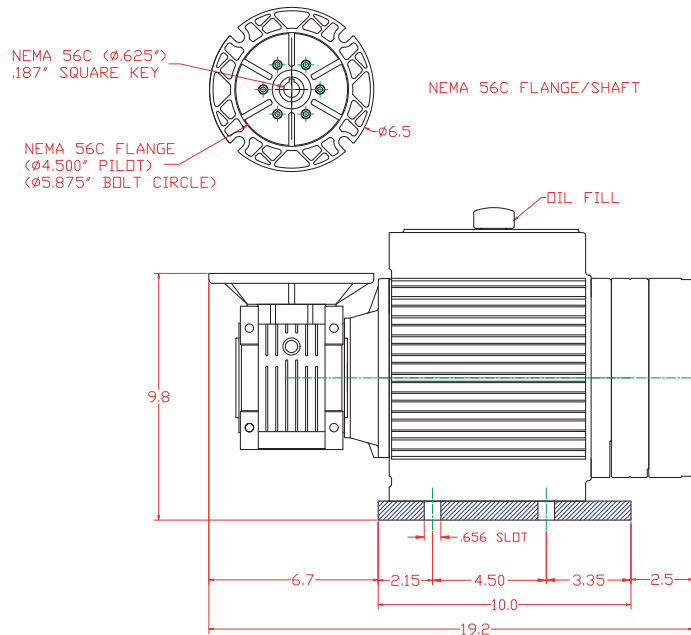

For accessories, options, and a system installation example, see pages 24-25.

## Pump Ordering Information

A complete pump order number contains 13 digits based on the specified pump materials listed below. Contact your Hydra-Cell sales representative for accompanying motor drive options.

1	2	3	4	5	6	7	8	9	10	11	12	13
P	5	0	0									

### Pump Model Size (Digits 1-4)

**P500** For all P500 Pumps

### Pump Version (Digit 5)

**N** NPT Ports  
**M** BSPT Ports

### Pump Head Material (Digit 6)

**S** 316 Stainless Steel  
**T** Hastelloy® C

### Diaphragm & O-ring Material (Digit 7)

**G** Viton®-XT  
**T** Buna-N-XS

### Check Valve Material (Digits 8-9)

#### (Valve Spring / Valve & Seat)

**SS** 316 SST / 316 SST  
**TT** Hastelloy® C / Hastelloy® C

### Gearbox Ratio (Digits 10-12)

<b>100</b>	100:1	(56C Motor Frame)
<b>080</b>	80:1	(56C Motor Frame)
<b>060</b>	60:1	(56C Motor Frame)
<b>050</b>	50:1	(56C Motor Frame)
<b>040</b>	40:1	(56C Motor Frame)
<b>A40</b>	40:1	(143/145TC Motor Frame)
<b>030</b>	30:1	(56C Motor Frame)
<b>A30</b>	30:1	(143/145TC Motor Frame)
<b>025</b>	25:1	(56C Motor Frame)
<b>A25</b>	25:1	(143/145TC Motor Frame)
<b>020</b>	20:1	(56C Motor Frame)
<b>015</b>	15:1	(56C Motor Frame)
<b>A15</b>	15:1	(143/145TC Motor Frame)
<b>B15</b>	15:1	(182/184TC Motor Frame)
<b>010</b>	10:1	(56C Motor Frame)
<b>A10</b>	10:1	(143/145TC Motor Frame)
<b>B10</b>	10:1	(182/184TC Motor Frame)
<b>007</b>	7.5:1	(56C Motor Frame)
<b>A07</b>	7.5:1	(143/145TC Motor Frame)
<b>B07</b>	7.5:1	(182/184TC Motor Frame)
<b>C07</b>	7.5:1	(213/215TC Motor Frame)
<b>005</b>	5:1	(56C Motor Frame)
<b>A05</b>	5:1	(143/145TC Motor Frame)
<b>B05</b>	5:1	(182/184TC Motor Frame)
<b>C05</b>	5:1	(213/215TC Motor Frame)
<b>D05</b>	5:1	(254/256TC Motor Frame)

### Base Plate (Digit 13)

**A** Aluminum (Epoxy painted)  
**H** Carbon Steel (Epoxy painted)  
 for B, C and D reducers

# P600 Pump Series

Capacities to 894.6 GPH - Rated to 1000 PSI

Hydra-Cell Metering Solutions meet or exceed API 675 performance standards for Steady-State Accuracy ( $\pm 1\%$ ), Linearity ( $\pm 3\%$ ), and Repeatability ( $\pm 3\%$ ).



## Performance\*

GPH Maximum Flow at Designated Pressure

GPH All Pumps		GPH Metallic Pump Heads Only		Pump RPM	Gear Ratio	Motor RPM
100 PSI	250 PSI	500 PSI	1000 PSI			
22.43	22.27	21.89	20.77	18	100:1	1800
28.03	27.79	27.31	26.05	22.5	80:1	
37.34	36.99	36.34	34.84	30	60:1	
44.80	44.35	43.57	41.87	36	50:1	
55.98	55.39	54.40	52.42	45	40:1	
74.62	73.79	72.46	70.01	60	30:1	
89.52	88.51	86.91	84.07	72	25:1	
111.9	110.6	108.6	105.2	90	20:1	
149.2	147.4	144.7	140.3	120	15:1	
223.7	221.0	216.9	210.7	180	10:1	
298.2	294.6	289.2	281.0	240	7.5:1	
447.3	441.8	433.7	421.7	360	5:1	3600
596.4	589.0	578.1	562.4	480	7.5:1	
894.6	883.4	867.1	843.7	720	5:1	

\* Capacity data is shown for pumps with elastomeric diaphragms. Consult factory for performance characteristics of pumps with PTFE diaphragms.

### Required Motor HP

1/4	1/2	3/4	1	1-1/2
2	3	5	7-1/2	10

**Pump Data**

Diaphragms per Liquid End	3
Flow Control	Electronic variable speed drive
Maximum Discharge Pressure	
Metallic Head:	1000 PSI (70 bar)
Non-Metallic Head:	Polypropylene- 250 PSI (17 bar) Kynar- 350 PSI (24 bar)
Maximum Suction Pressure	250 PSI (17 bar)
Maximum Temperature	
Metallic Head:	250°F (121°C)*
Non-Metallic Head:	140°F (60°C)
Suction Port	1-1/2 inch NPT or BSPT
Discharge Port	1 inch NPT or BSPT
Weight (less motor)	
Metallic Head:	141 lbs (64 kg)
Non-Metallic Head:	106 lbs (48 kg)
Dimensions (less motor)**	
Metallic Head:	21.0" W x 10.7" D x 11.2" H (533 mm W x 272 mm D x 285 mm H)
Non-Metallic Head:	21.8" W x 10.7" D x 11.2" H (554 mm W x 272 mm D x 285 mm H)

\* Consult factory for correct component selection for temperatures above 160°F (71°C).  
\*\* For 56C motor frame only. Consult factory for other motor frame sizes.

**Representative Dimensional Drawings**

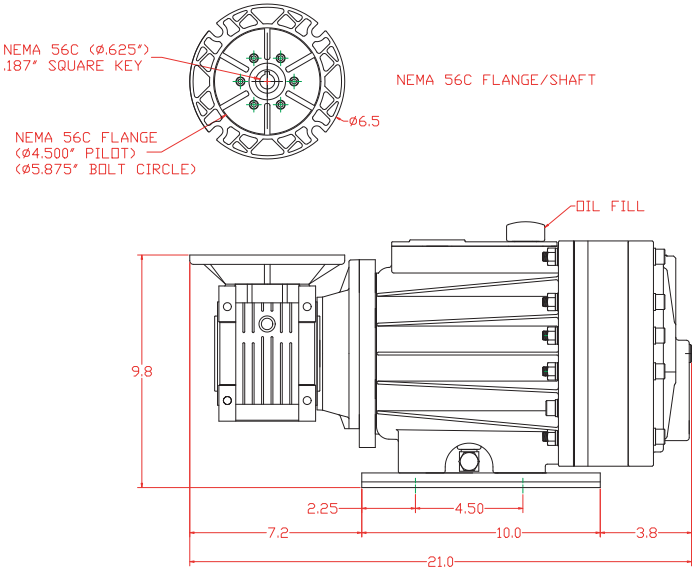

For accessories, options, and a system installation example, see pages 24-25.

**Pump Ordering Information**

A complete pump order number contains 13 digits based on the specified pump materials listed below. Contact your Hydra-Cell sales representative for accompanying motor drive options.

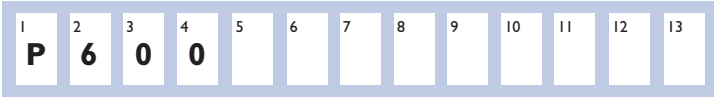

**Pump Model Size (Digits 1-4)**

**P600** For all P600 Pumps

**Pump Version (Digit 5)**

**N** NPT Ports  
**M** BSPT Ports

**Pump Head Material (Digit 6)**

**C** Cast Iron  
**M** Kynar®  
**P** Polypropylene  
**S** 316 Stainless Steel  
**T** Hastelloy® C

**Diaphragm & O-ring Material (Digit 7)**

**E** EPDM  
**G** Viton®-XT  
**J** PTFE  
**P** Neoprene  
**T** Buna-N-XS

**Check Valve Material (Digits 8-9)**

**(Valve Spring / Valve & Seat)**

**SS** 316 SST / 316 SST  
**TT** Hastelloy® C / Hastelloy® C  
**SC** 316 SST / Ceramic  
**TC** Hastelloy® C / Ceramic

**Gearbox Ratio (Digits 10-12)**

<b>100</b>	100:1	(56C Motor Frame)
<b>080</b>	80:1	(56C Motor Frame)
<b>060</b>	60:1	(56C Motor Frame)
<b>050</b>	50:1	(56C Motor Frame)
<b>040</b>	40:1	(56C Motor Frame)
<b>A40</b>	40:1	(143/145TC Motor Frame)
<b>030</b>	30:1	(56C Motor Frame)
<b>A30</b>	30:1	(143/145TC Motor Frame)
<b>025</b>	25:1	(56C Motor Frame)
<b>A25</b>	25:1	(143/145TC Motor Frame)
<b>020</b>	20:1	(56C Motor Frame)
<b>A20</b>	20:1	(143/145TC Motor Frame)
<b>015</b>	15:1	(56C Motor Frame)
<b>A15</b>	15:1	(143/145TC Motor Frame)
<b>010</b>	10:1	(56C Motor Frame)
<b>A10</b>	10:1	(143/145TC Motor Frame)
<b>B10</b>	10:1	(182/184TC Motor Frame)
<b>007</b>	7.5:1	(56C Motor Frame)
<b>A07</b>	7.5:1	(143/145TC Motor Frame)
<b>B07</b>	7.5:1	(182/184TC Motor Frame)
<b>C07</b>	7.5:1	(213/215TC Motor Frame)
<b>005</b>	5:1	(56C Motor Frame)
<b>A05</b>	5:1	(143/145TC Motor Frame)
<b>B05</b>	5:1	(182/184TC Motor Frame)
<b>C05</b>	5:1	(213/215TC Motor Frame)

**Base Plate (Digit 13)**

**C** Carbon Steel (Epoxy painted)  
**H** Carbon Steel (Epoxy painted)  
for B and C reducers

## Hydra-Cell System Options & Accessories

System Installation Example

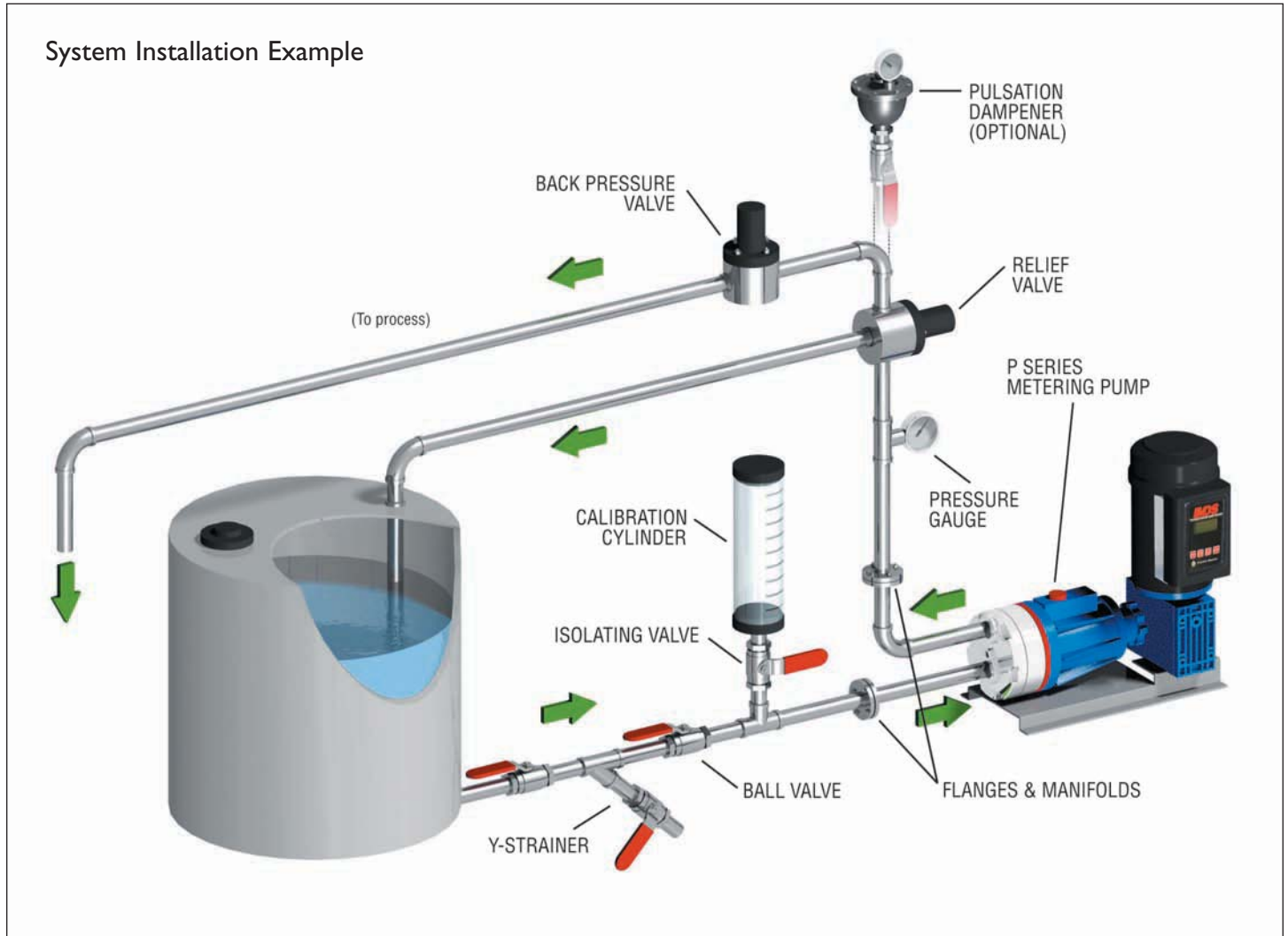

Hydra-Cell pumps are just one facet of a complete Hydra-Cell “Metering Solutions” system. We can furnish all components in your pumping system, individually tailored to your specific processing needs. For complete details, contact Hydra-Cell, your Hydra-Cell sales representative, or Hydra-Cell distributor.

- Calibration Cylinders
- Back Pressure Valves
- Pressure Relief Valves
- Pulsation Dampeners
- Motors - Motor Adapters - VFDs - Controllers
- Diaphragm Materials
- Liquid End & Check Valve Materials
- Gearbox Ratios
- Manifolds & Flanges
- Strainers
- Suction Accumulators
- Actuating Oils
- Witnessed & Non-Witnessed Testing
- Drawing Packages
- OEM Paint & Nameplate Customization



**Motor Adapters - VFDs - Controllers - Motors**



**Custom Motor Controller**



**Variety of Diaphragm Materials**



**Metallic or Non-Metallic  
Liquid End & Check Valve Materials**

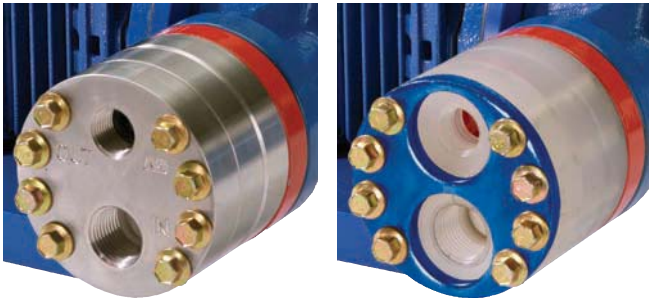

**Pulsation Dampeners**



**OEM Paint & Nameplate  
Customization Available**



**Pressure Relief & Back Pressure Valves**



**Different Gearbox Ratios**



**PVC or Glass Calibration Cylinders**



# Hydra-Cell Bare Shaft Pumps for Metering



In certain dosing applications, Hydra-Cell pumps without the gear reducers (bare shaft pumps) are an ideal alternative to metering pumps. Hydra-Cell bare shaft pumps should be considered

instead of a Hydra-Cell Metering Solutions system when any of the following conditions apply:

- Flow capacities required exceed those of Hydra-Cell Metering Solutions pumps (see page 10)
- Space or application parameters dictate the use of direct or belt drives
- Acquisition cost is the primary consideration
- The application requires metering, but performance characteristics do not have to exceed API 675 standards for steady-state accuracy ( $\pm 1\%$ ), linearity ( $\pm 3\%$ ) and repeatability ( $\pm 3\%$ )

## Capacities & Ratings

Model*	Maximum Capacity (GPH)	Maximum Discharge Pressure (PSI)		Maximum Temperature (°F)		Maximum Suction Pressure (PSI)	Rated RPM for Metering
		Non-Metallic	Metallic	Non-Metallic	Metallic		
F20	36.6	250	1500	140°	250°	250	1050
M03	155.4	250	1000	140°	250°	250	1440
D04	156.6	N/A	2500	N/A	250°	500	1440
D10	492.0	250	1000	140°	250°	250	1440
D15	813.0	N/A	2500	N/A	250°	500	1440
H25	1278.0	250	1000	140°	250°	250	1050
D35	2280.0	250	1200	140°	250°	250	1050

\* Ratings are for X-Cam design

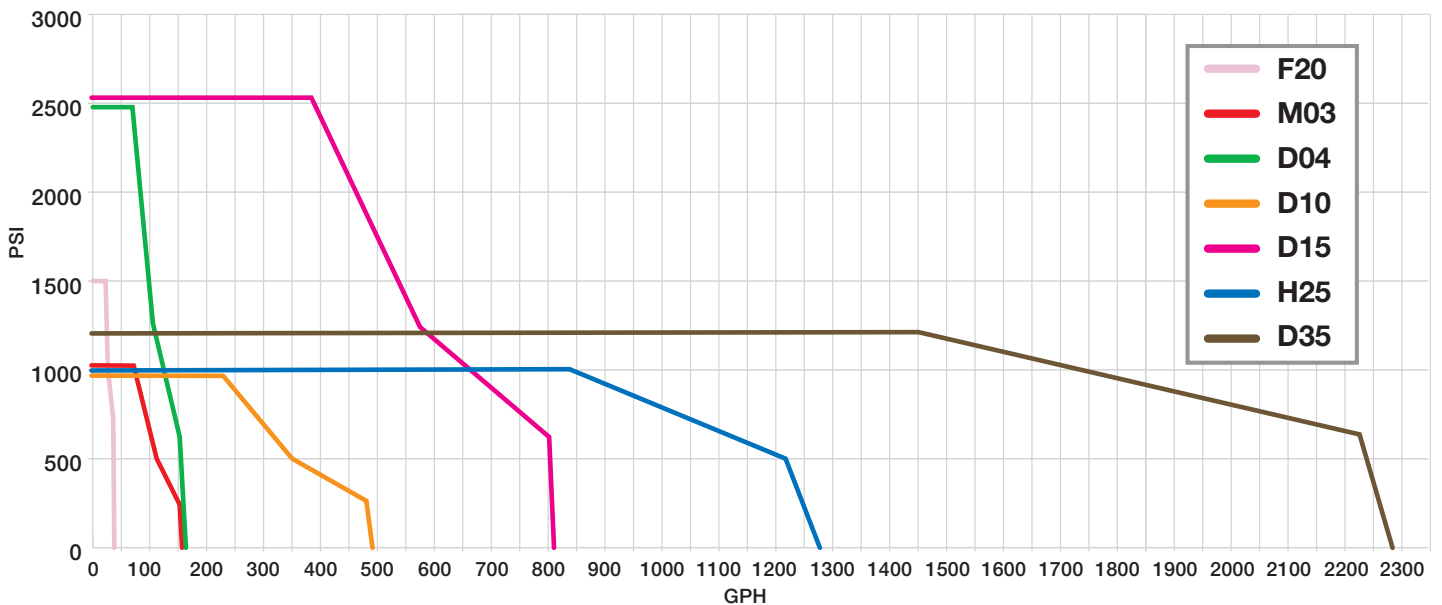

# Hydra-Cell Worldwide Sales & Service



Hydra-Cell pumps are sold and serviced worldwide by a comprehensive network of factory-trained pump distributors. As specialists in pump technologies, our distributor organizations offer you a vital local resource for technical expertise, product training, sales and service.

Hydra-Cell distributors are located in more than 40 countries worldwide. In North America specifically, there are more than 100 Hydra-Cell distributor locations to provide local availability for every major industrial marketplace.

**Contact us for the distributor location nearest you.**

- |                |                 |                |
|----------------|-----------------|----------------|
| Argentina      | Iceland         | Romania        |
| Australia      | India           | Singapore      |
| Austria        | Indonesia       | South Africa   |
| Belgium        | Ireland         | Spain          |
| Brazil         | Italy           | Sweden         |
| Canada         | Japan           | Switzerland    |
| China          | Korea           | Taiwan         |
| Czech Republic | Latvia          | Thailand       |
| Denmark        | Lithuania       | Turkey         |
| Finland        | Malaysia        | United Kingdom |
| France         | Mexico          | United States  |
| Germany        | The Netherlands | Uruguay        |
| Greece         | New Zealand     | Venezuela      |
| Holland        | Norway          | Vietnam        |
| Hong Kong      | Poland          |                |
| Hungary        | Puerto Rico     |                |

# Hydra·Cell<sup>®</sup>

---

## METERING SOLUTIONS<sup>™</sup>



### **Wanner Engineering, Inc.**

1204 Chestnut Avenue  
Minneapolis, MN 55403 USA  
Phone: 612-332-5681  
Fax: 612-332-6937  
Toll-Free Fax (USA): 800-332-6812  
Email: [sales@wannereng.com](mailto:sales@wannereng.com)  
[www.Hydra-Cell.com/metering](http://www.Hydra-Cell.com/metering)



### **Wanner International Ltd.**

Units 8 & 9, Fleet Business Park  
Sandy Lane  
Church Crookham, Hampshire GU52 8BF, England  
Phone: +(44) 01252 816847  
Fax: +(44) 01252 629242  
Email: [sales@wannerint.com](mailto:sales@wannerint.com)  
[www.WannerInt.com](http://www.WannerInt.com)



### **Wanner Pumps Ltd.**

Room 1111, 11/F New Kowloon Plaza  
38 Tai Kak Tsui Road  
Tai Kak Tsui, Kowloon, HONG KONG  
Phone: (852) 3428 6534  
Fax: (852) 3188 9145  
Email: [jloo@wannereng.com](mailto:jloo@wannereng.com)